

YOUNGSTOWN  
YACHT CLUB  
NIAGARA-ON-THE-LAKE  
SAILING CLUB

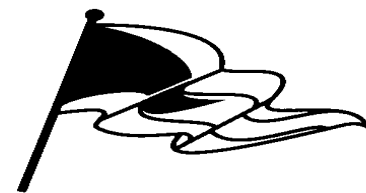

The organizing authority is the host club  
(see the race schedule, attachment C)

## 2011 Notice of Race and Sailing Instructions

For the Furlined, Seven-Year, October Cup (River Races)

Cyril Read, Sheet Tailers', Lincoln Trust and 1812 Series (Lake Races)

### 1 RULES

- 1.1 The series will be governed by the rules as defined in *The Racing Rules of Sailing*.
- 1.2 Prescriptions of the national authority of the host club (see the race schedule attachment C) will apply.
- 1.3 When racing one-design a boat shall follow the rules of her class.
- 1.4 When racing PHRF a boat shall follow the PHRF-Lake Ontario (PHRF-LO) rules.
- 1.5 In the 2<sup>nd</sup> sentence of rule 49.2 change "wire" to "wire or Dyneema®".

### 2 ELIGIBILITY AND ENTRY

- 2.1 The series are open to boats owned by members of the Niagara-on-the-Lake Sailing Club (NOLSC) or the Youngstown Yacht Club (YYC) meeting the relevant class rules if racing one-design or PHRF-LO rules if racing PHRF. Other boats may be permitted to race at the sole discretion of the VC-Fleet of the host club.
- 2.2 Eligible boats may enter by registering the Boat Name, Type and Sail Number with the VC-Fleet of her owner's club. The VC-Fleet of YYC can be contacted at [vcfleet@yyc.org](mailto:vcfleet@yyc.org) and the VC-Fleet of NOLSC can be contacted at: [fleet@niagarasailing.on.ca](mailto:fleet@niagarasailing.on.ca). Boats failing to register may be scored Did Not Compete without a hearing.
- 2.3 A boat that has been scored other than Did Not Compete in one race of a series shall remain in that class through-out the series.

### 3 SCHEDULE OF RACES

- 3.1 The schedule in attachment C shows the dates of racing.
  - (a) Attachment C shows the number of races in the Fall series.
  - (b) Except for the Fall series one race is scheduled for each day.
- 3.2 The scheduled time of the warning signal for the first race each day is:
  - (a) 1330 for the river races,
  - (b) 1840 for the Cyril Read, Sheet Tailers' and Lincoln Trust series,
  - (c) 1830 for the 1812 series,
  - (d) 1015 for the Fall Series.
- 3.3 After a long postponement, to alert boats that a race or sequence of races will begin soon, an orange flag will be displayed with one sound for at least four minutes before a warning signal is displayed.

### 4 MEASUREMENTS

Each boat racing PHRF or NFS shall produce a valid rating certificate or have one pending.

### 5 CLASS SPLITS

- 5.1 For the Furlined series all boats will race in NFS.
- 5.2 For the Seven-Year and October Cup series all boats will race in PHRF I or NFS.
- 5.3 For the lake races the PHRF racing classes will be split as follows:

March, 2011

- (a) Boats with a rating no greater than 105 will race in PHRF I or IA. Assignments to these sub-classes will be posted on the notice board by 0900 on the first day of the series.
- (b) Boats with a rating no less than 108 will race PHRF II

5.4 5 or more boats shall be registered to form a one-design class.

**6 NOTICES TO COMPETITORS**

Notices to competitors will be posted on the official notice boards located at the north end of the NOLSC main clubhouse and at the YYC clubhouse. Notices will be duplicated on the “Notice Board” page on the web site of the host club. Failure to post notices on the web site in a timely fashion will not be grounds for redress.

**7 CHANGES TO SAILING INSTRUCTIONS**

Any change to the sailing instructions will be posted before 0900 on the day it will take effect, except that any change to the schedule of races will be posted by 2000 on the day before it will take effect.

**8 SIGNALS MADE ASHORE**

- 8.1 Signals made ashore will be displayed at the flagpole nearest to the riverfront at the host club.
- 8.2 Except when the flagpole ashore is being used to display starting signals, when flag AP is displayed ashore, “1 minute” is replaced with “not less than 45 minutes” in the race signal AP.
- 8.3 When flag Y is displayed ashore, rule 40 applies at all times while afloat. This changes the Part 4 preamble.

**9 SCHEDULE OF RACES**

The schedule of races can be found in Attachment C.

**10 CLASS AND IDENTIFICATION FLAGS**

10.1 Class flags and identification flags will be:

<i>Class</i>	<i>Class Flag</i>	<i>Identification Flag</i>
Shark	Numeral Pennant 1	None while racing one-design
Not Flying Spinnaker (NFS)	Numeral Pennant 2	White (none for the Furlined series)
PHRF II	Numeral Pennant 3	Yellow
Beneteau 10R	Numeral Pennant 4	None while racing one-design
Beneteau 36.7	Numeral Pennant 5	None while racing one-design
PHRF I & IA	Numeral Pennant 6	Black

10.2 Identification flags shall be no less than 8” high x 12” wide and shall be prominently displayed from the backstay.

**11 RACING AREAS**

- 11.1 The racing areas are:
  - (a) the Niagara river in front of NOLSC for river races,
  - (b) mark C (see 11.2 below) for lake races.
- 11.2 Mark C at the centre of the Olympic circle is located approximately 1.1 miles at a bearing of 55° mag. from the Niagara Light and Bell Buoy G3. The approximate position of C is N43°17.20’, W079°03.45’.

**12 THE COURSES**

- 12.1 The diagrams in Attachment A show the courses, including the approximate angles between legs, the order in which marks are to be passed, and the side on which each mark is to be left.
- 12.2 No later than the warning signal, the race committee signal boat will display the course designation as indicated on Attachment A.
- 12.3 During the 2<sup>nd</sup> or subsequent starts in a sequence a boat whose preparatory signal has not been made shall not cross the starting line. This modifies rule 28.2.

### **13 MARKS**

- 13.1** The relative locations of marks C and 1 through 8 are illustrated in Attachment B.
- 13.2** Marks C and 1 through 8 are vertical cylinders identified respectively by:
- (a) a black C, 1, 3, 5 or 7 on a white background or
  - (b) a white 2, 4, 6 or 8 on a black background.
- 13.3** G is a faded red ball.
- 13.4** G3 is the Niagara light and bell buoy at approximately N43°16'24.3", W079° 04'30.8".
- 13.5** R2 is the Niagara Bar light buoy at approximately N43°19'02.4", W079° 04'14.1".
- 13.6** SM1 is the north speed marker at approximately N43°15.28' W79°03.31".
- 13.7** SM2 is the middle speed marker at approximately N43°14.68' W79°03.28".
- 13.8** SM3 is the south speed marker at approximately N43°14.26' W79°03.30".
- 13.9** MB2 is the second NOLSC mooring ball from the NOLSC harbour entrance.
- 13.10** Other marks as indicated on the race committee white board.
- 13.11** The starting and finishing marks will be:
- (a) the NOLSC river-side flagstaff at the southwest end and the
    - (i) US Border Protection surveillance tower (ST) located approximately at N43°15.57' W79°03.45 at the NE end for starts
    - (ii) either ST or MB2, as identified by the course designation for the finish for river races,
  - (b) the race committee signal boat at the starboard end and Mark C at the port end for the lake races.

### **14 THE START**

- 14.1** The starting line will be:
- (a) a staff displaying an orange flag at NOLSC and the NE starting mark for river races,
  - (b) a staff displaying an orange flag on the signal boat and the port-end starting mark for lake races.
- 14.2** Boats whose warning signal has not been made shall avoid the starting area during the starting sequence for other races.
- 14.3** The starting sequence will typically follow the class sequence in 10.1 above. Failure of the race committee to follow that sequence will not be grounds for redress.
- 14.4** More than one class may be started at one time.
- 14.5** A boat starting later than 4 minutes after her starting signal will be scored Did Not Start without a hearing. This changes rule A4.

### **15 THE FINISH**

- 15.1** The finishing line will be between a staff displaying an orange flag on:
- (a) the finishing mark at the southwest end and the northeast-end finishing mark for river races.
  - (b) the finishing mark at the starboard end and the port-end finishing mark for lake races.
- 15.2** Under rule 23.1, if reasonably possible a boat not *racing* shall not interfere with a boat that is racing.
- 15.3** If the committee boat is not on station, boats shall cross an imaginary finishing line perpendicular to the last leg within 50 yards of the mark, leaving the mark to port (or as appropriate for river races). The finishing time shall be submitted to the VC-Fleet of the host club no later than noon the next day. This instruction changes rule 34 and US Sailing prescriptions to rule 34 when US Sailing prescriptions apply.

### **16 TIME LIMITS**

- 16.1** The time limit is:
- (a) 2 hours and 15 minutes from the class starting signal for the river races.
  - (b) 2 hours from the class starting signal for the lake races.

March, 2011

- 16.2** Boats failing to finish within:
- (a) 3 hours after the class starting signal for the river races, or
  - (b) 2 hours and 30 minutes after the class starting signal for the lake races
- will be scored Did Not Finish without a hearing. This changes rules 35, A4 and A5.

## **17 PROTESTS AND REQUESTS FOR REDRESS**

- 17.1** Protest forms are available from the main office of NOLSC or YYC during business hours. Protests and requests for redress or reopening shall be delivered to VC-Fleet of NOLSC or YYC or designee within the appropriate time limit.
- 17.2** The protest time limit is 1 hour after the race committee has signalled her return to her mooring.
- 17.3** Notices will be posted no later than 30 minutes after the protest time limit to inform competitors of hearings in which they are parties or named as witnesses. Hearings will be held in the protest room, located at the southeast corner on the 2<sup>nd</sup> floor of the NOLSC clubhouse if NOLSC is the host club or the YYC clubhouse if YYC is the host club, beginning at 1930 on the Monday following the race.
- 17.4** Notices of protests by the race committee or protest committee will be posted to inform boats under rule 61.1(b).
- 17.5** Penalties for breaches of instructions 4, 10.2, 14.2, 19, 20 or 21 may be less than disqualification if the protest committee so chooses. The scoring abbreviation for a discretionary penalty imposed under this instruction will be DPI.

## **18 SCORING**

- 18.1** The column *series* in race schedule attachment C has a number preceding the divide symbol ‘/’ (numerator).
- (a) When *numerator* or fewer races have been completed, a boat’s series score will be the total of her race scores.
  - (b) When more than *numerator* races have been completed, a boat’s series score will be the total of her race scores excluding her worst score.
- 18.2** PHRF corrected times will be calculated using the “PHRF-LO Time-on-Time” method.

## **19 SAFETY REGULATIONS**

A boat that retires from a race shall notify the race committee as soon as possible.

## **20 TRASH DISPOSAL**

Boats shall not put trash in the water.

## **21 RADIO COMMUNICATION**

Except in an emergency, a boat shall neither make radio transmissions while racing nor receive radio communications not available to all boats. This restriction also applies to mobile telephones.

The race committee may communicate information on VHF 72. Failure to make these communications or the sequence in which they are made shall not be ground for redress.

## **22 PRIZES**

The list of prizes can be found in Attachment D.

## **23 DISCLAIMER OF LIABILITY**

Competitors participate in the regatta entirely at their own risk. See rule 4, Decision to Race. The organizing authority will not accept any liability for material damage or personal injury or death sustained in conjunction with or prior to, during, or after the regatta.

## **24 INSURANCE**

Each participating boat shall be insured with adequate third-party liability insurance.

## **25 FURTHER INFORMATION**

For further information please contact the VC-Fleet of YYC at [vcfleet@yyc.org](mailto:vcfleet@yyc.org) or the VC-Fleet of NOLSC at [fleet@niagarasailing.on.ca](mailto:fleet@niagarasailing.on.ca).

# ATTACHMENT A RACE COURSES

## Course D – A Windward Leeward Course

Designation: *Dab* where *a* and *b* are the numerals designating Olympic circle marks (see attachment B)

Example: D62 indicates that mark *a* will be Olympic circle mark 6 and *b* will be Olympic circle mark 2

### All classes except Sharks

**Start – a – b – a – b – a – b – a – b - Finish**

Example: Start – 6 – 2 – 6 – 2 – 6 – 2 – 6 – 2 - Finish

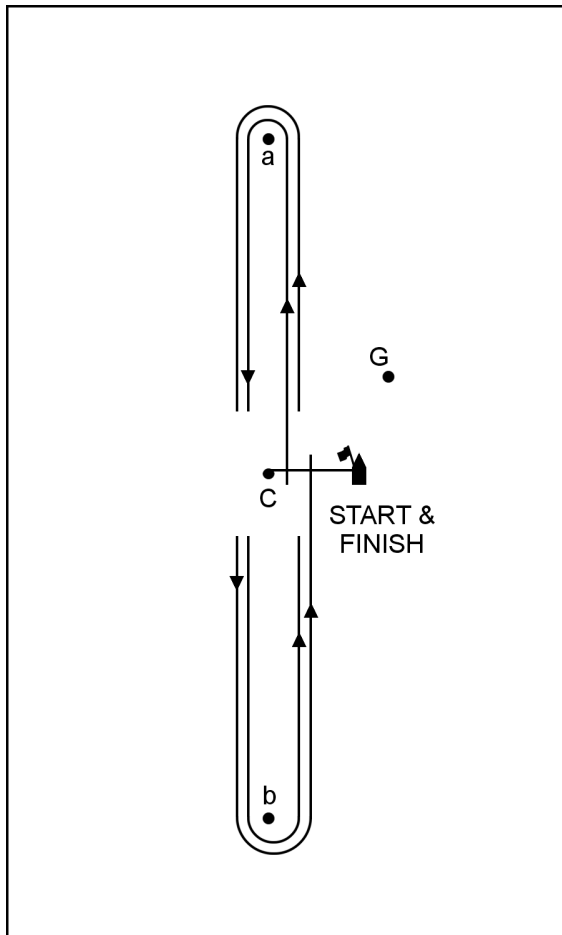

Neither C nor the signal boat are marks of the course except when starting, finishing or when instruction 14.2 applies.

### Sharks Only

**Start – a – G – a – G – a – G – a - Finish**

Example: Start – 6 – G – 6 – G – 6 – G – 6 - Finish

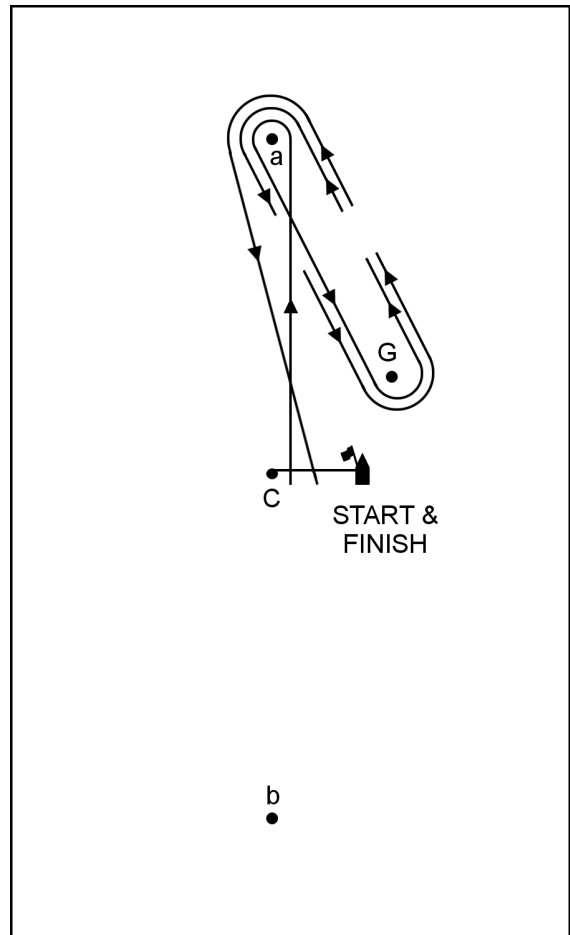

G will be set approximately 150 yards toward the course side of the starting line and slightly to starboard of the signal boat (position in diagram exaggerated for clarity).

The course may be shortened at *b* in which case the signal boat will relocate to the vicinity of *b*. When the signal boat leaves her starting position:

- If the lead boat is on leg ‘a – G’, boats shall sail to *b* for the finish, or
- If the lead boat is on leg ‘G – a’, boats shall round *a* then sail to *b* for the finish.

## Course E – A Course Where Course D is not Suitable

Designation: E followed by a list of marks to round. Marks shall be left to port unless otherwise stated in the course designation.

Example: E81C

## ATTACHMENT B

### YYC-NOLSC OLYMPIC CIRCLE COURSE CHART

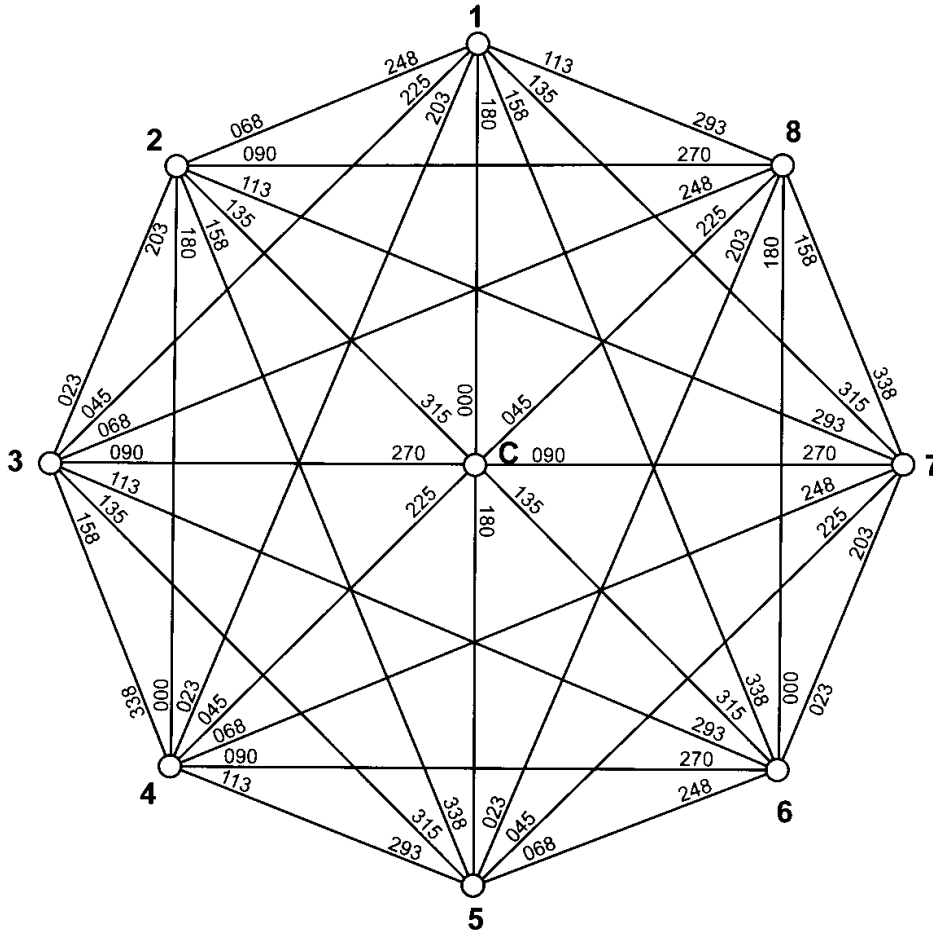

**DISTANCE TABLE (Nautical Miles)**

To From	C	1	2	3	4	5	6	7	8
C	-	0.75	0.75	0.75	0.75	0.75	0.75	0.75	0.75
1	0.75	-	0.57	1.06	1.39	1.50	1.39	1.06	0.57
2	0.75	0.57	-	0.57	1.06	1.39	1.50	1.39	1.06
3	0.75	1.06	0.57	-	0.57	1.06	1.39	1.50	1.39
4	0.75	1.39	1.06	0.57	-	0.57	1.06	1.39	1.50
5	0.75	1.50	1.39	1.06	0.57	-	0.57	1.06	1.39
6	0.75	1.39	1.50	1.39	1.06	0.57	-	0.57	1.06
7	0.75	1.06	1.39	1.50	1.39	1.06	0.57	-	0.57
8	0.75	0.57	1.06	1.39	1.50	1.39	1.06	0.57	-

Note that the courses and distances shown above are for information only and that any inaccuracies are not subject to protest.

March, 2011